

BBQ Tool Kit

Kit Features:

- Easy to turn into tapered handles
- Minimum parts - easy to assemble
- Stainless steel construction
- Overall Length: Spatula - 16-3/4"
- Fork - 16" • Tongs - 15-1/2"
- Wood Required: 1-1/4" x 6" & 1-1/4" x 7" Long (2 of each size)



Required Accessories:

- Bottle Stopper Chuck System #PKBSYST
- 11/32" Drill Bit #PK1132
- Epoxy - Mid cure glue
- Aussie or Mahoney's Oil
- Large Slotted Ferrules (2)

DIAGRAM A / PARTS LAYOUT

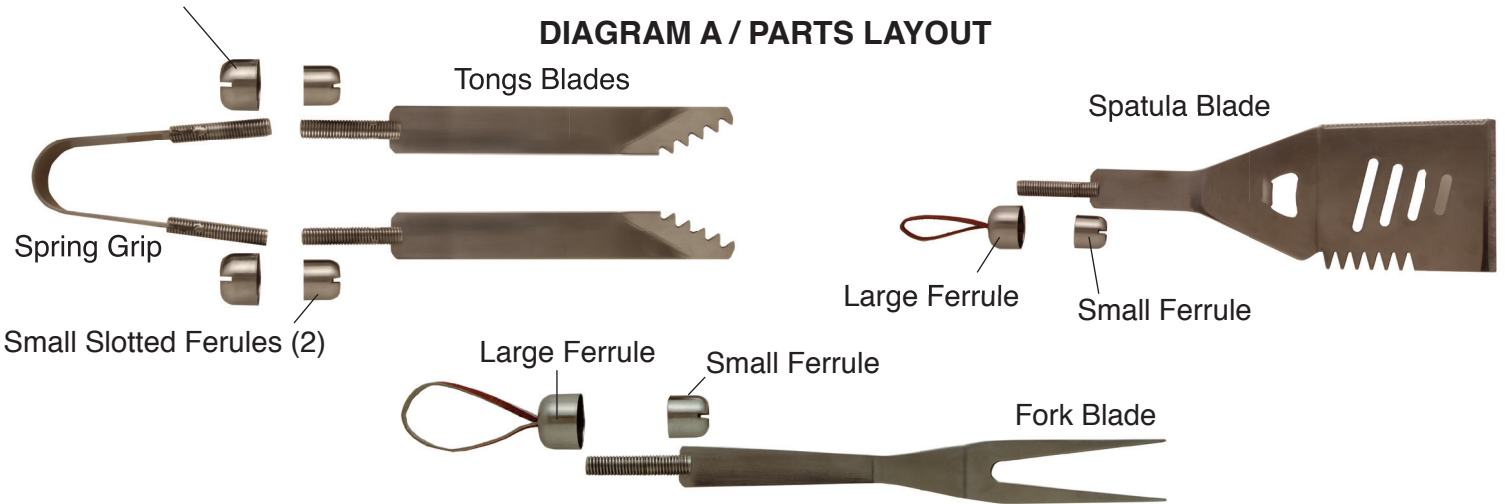

Preparing the Blank:

- Mark the center over the ends of the blanks.
- Tong blanks Drill 11/32" holes 2-1/2" deep. Spatula, Fork blanks (*In the 7" long blank one hole only*)

DIAGRAM B / TURNING THE BLANKS

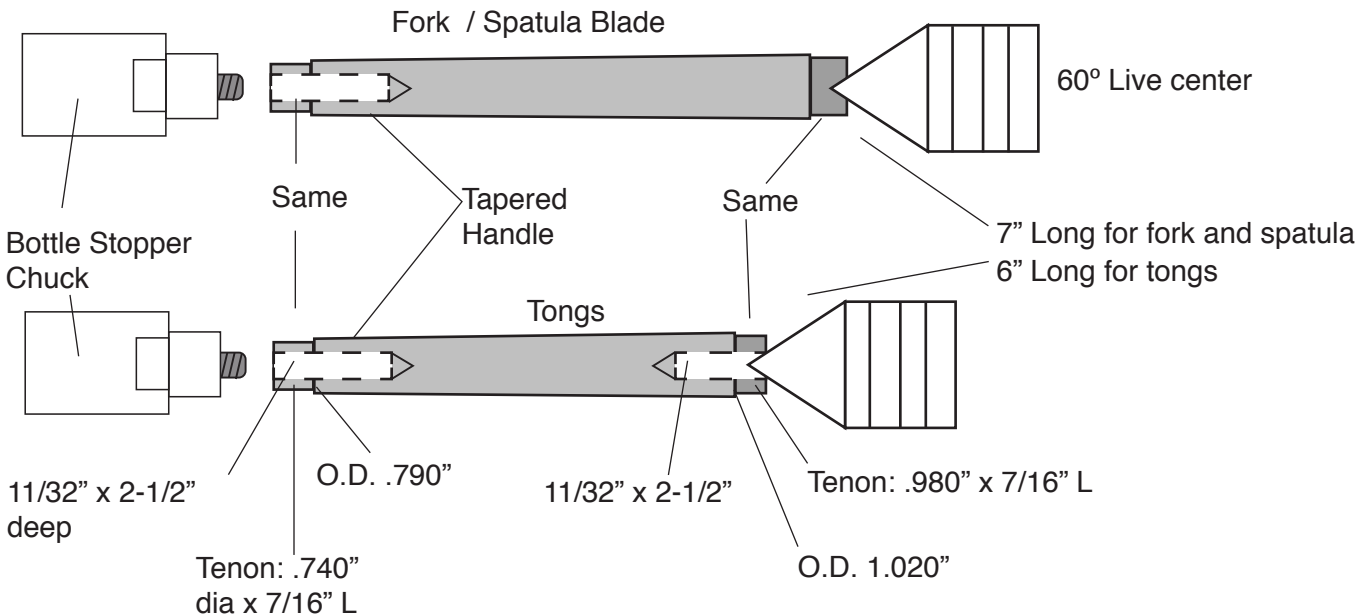

Turning the Blank:

- 1) Insert and mount each blank onto a bottle stopper chuck and a Live center point on the tailstock end. See Dia. B
- 2) Turn the handle in a taper, same as in diagram B. Turn tenons as shown - measure the I.D. & O.D. of the ferrule for best results.
- 3) Sand and finish the wood in all handles. Use either Aussie or Mahoney's oil to protect the wood.
- 4) Remove handles, ream the holes w/a 10mm bit.

Tongs Assembly:

- Squeeze epoxy glue into both large diameter holes.
- Spread epoxy glue inside both large ferrules.
- Slide each ferrule over the tenon with a twisting motion to spread the glue around.
- Grab and insert the threaded shanks of the bent connector into the opening. Adjust the ferrules to clear into the slots. Stop when the top of the bolt is even with the ferrule. See Dia. C
- Repeat the same process with the small ferrules.
- Adjust each tung so the two are parallel and the teeth are in position to grab the object.

Diagram C: Ferrule Assembly

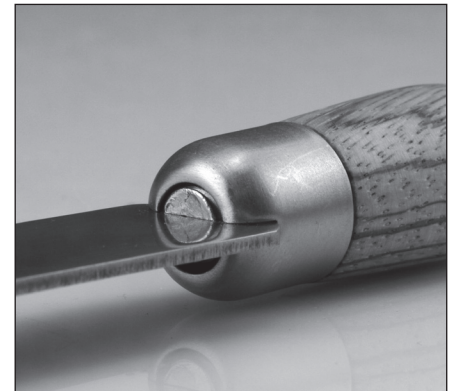
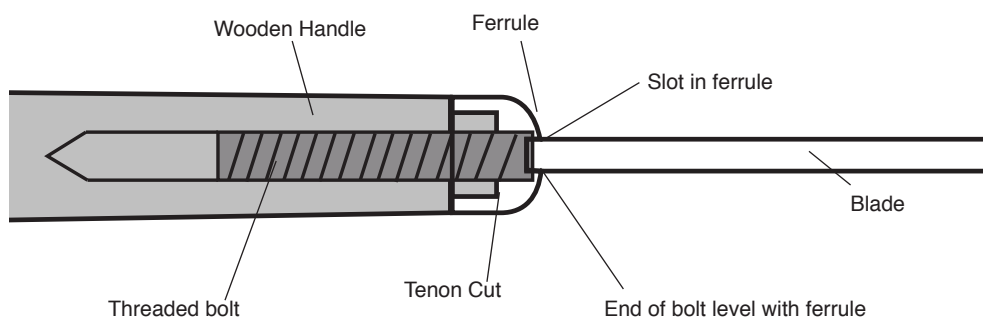

Installing Blade

Fork / Spatula Assembly:

Follow the same process for the blade end (small ferrule). Glue the large ferrule (with straps) over the tenon on the large diameter end of the turned barrel.

Finishing:

For best results, use Aussie Oil (on the lathe) or Mahoney's Oil (off the lathe) - buff off the lathe for a polished finish.