

# MAJESTIC JUNIOR Roller Ball and Fountain Pen Kits

- #PKMAJTPJR—Roller Ball Pen; Rhodium and Black T/N
- #PKMAFTPJR—Fountain Pen; Rhodium and Black T/N
- #PKMAJGPJR—Roller Ball Pen; Rhodium and Gold Plate
- #PKMAFGPJR—Fountain Pen; Rhodium and Gold Plate

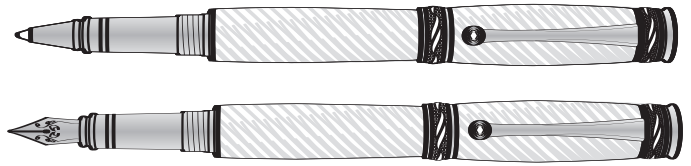

## KIT FEATURES

- A slender redesign of our popular Majestic Pen.
- Heavy plating and Swarovski™ crystal in clip
- Premium roller ball refill style—#PKSCHR
- Requires at least 3/4" x 3/4" x 5" Blank
- Overall dimension 5-5/8"

## REQUIRED ACCESSORIES:

- 7mm pen mandrel
- #PKMAJJRBU—3-piece bushing set
- #PK105MM—10.5mm Drill Bit
- #PKPLI-DB—.492" Drill Bit
- #PKMAJJRBTs—2-piece Barrel trimmer sleeve set
- #PKTRIMKIT—Universal barrel trimmer
- 2-part epoxy glue or insta-cure glue (cyanoacrylate).

DIAGRAM A - Parts List

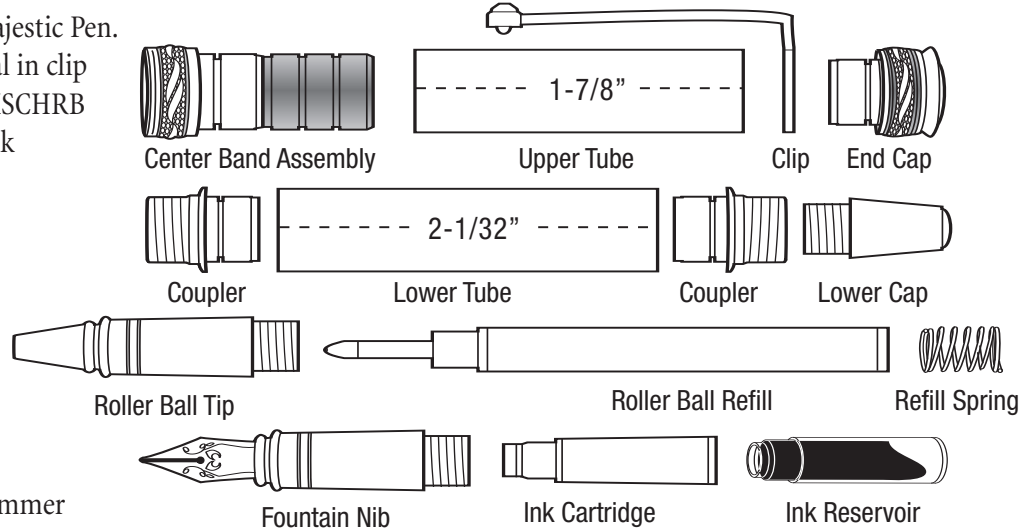

## PREPARING THE BLANKS:

- Prepare a master blank of at least 3/4" square. Cut two sections to the length of each tube. (Add 1/16" for trimming)
- Mark the center of each blank.

- Upper blank (shorter tube)—drill a .492" hole through.
- Lower blank (longer tube)—drill a 10.5mm hole through.

**NOTE:** Sand the tubes using 220-grit abrasive for better adhesion.

- Glue each tube in the proper blank. Spread the glue over each tube. Insert the tube into the blank with a twisting motion to spread the glue evenly inside. Center each tube lengthwise inside the blank.
- When glue dries, square the ends of each blank. Using a 10mm barrel trimmer with adapter sleeves (#PKMAJJRBTs), mount the proper sleeve (large diameter for the short tube, smaller diameter for the longer tube) over the shank. Trim the blank down flush with the brass tube.

## TURNING THE BLANKS:

- Mount 7mm spacer bushings on the mandrel followed by the tip bushing (shorter diameter) wide end first. Slide the lower blank (long) on next. Follow with the center bushing, narrow diameter first. Slide on the upper blank (short) and follow with the cap bushing, narrow end first. Add additional spacer bushings as necessary to overlap the mandrel threads. Thread on the lock-nut hand tight. Bring the tailstock in snug to the mandrel. Tighten the lock-nut for turning. Do not over-tighten the lock nut—it may damage the mandrel.
- Turn the blanks down close to the bushings. Follow with abrasives until the tube diameters are flush with the bushings. Finish with your choice of polish.

DIAGRAM B • Turning the blanks

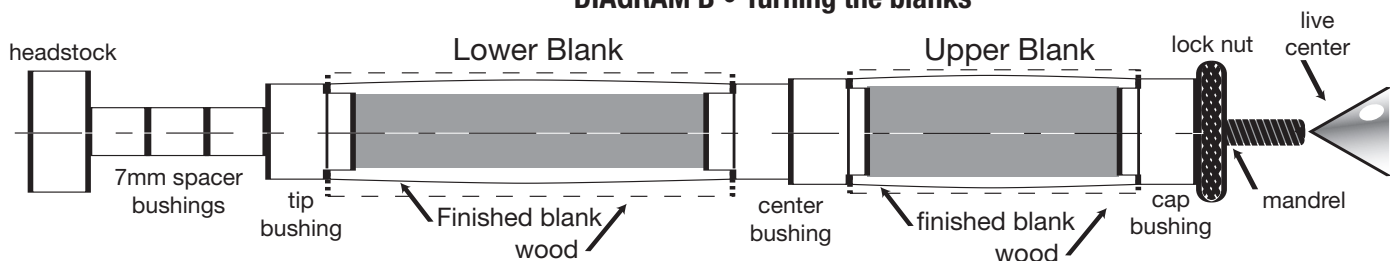

**ASSEMBLY:**

**NOTE:** Line up the components according to **DIAGRAM C**. To avoid damage to components when assembling pen, use vise with covered jaws or PSI #PENPRESS3.

- Press the center band assembly into the upper barrel (shorter tube).
- Press the end cap and clip into the opposite end of the upper barrel.
- Press both couplers into the either end of the lower barrel.
- Thread the lower cap into the top of the lower barrel.

**DIAGRAM C - Pen Assembly**

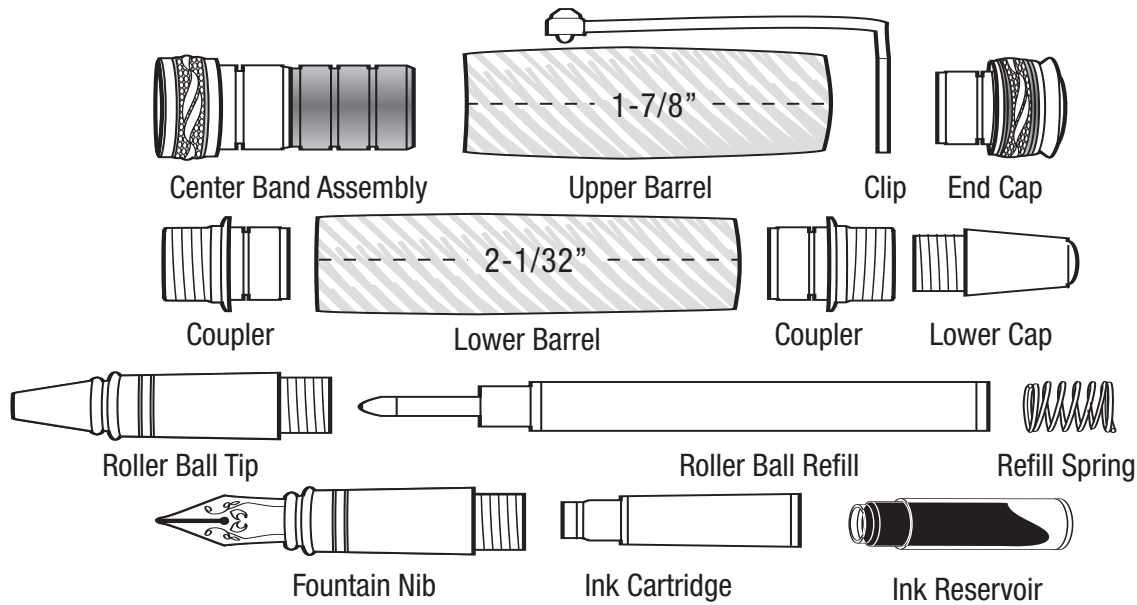

**TIPS**

- The threads on the pen cap have three starting points so you can quickly close the pen in any of these positions.

**ROLLER BALL**

- Drop the refill spring into the lower barrel.
- Discard roller ball refill cover. Insert the roller ball refill, flat end first, into the threaded coupler over the spring.
- Thread the roller ball tip over the refill into the threaded coupler.

**FOUNTAIN PEN**

- Press the ink cartridge, narrow end first into the back of the fountain nib. Push to break the seal (or use PSI refillable reservoirs #PKPUMP5), then press lightly on the nib to advance the ink forward.
- Thread the fountain nib assembly over the threaded coupler.

**BUSHINGS**

**DIAGRAM D • PKMAJJRBU**

