

Chef's Pizza Cutter Kit

william wood-write

penblanks.ca

Kit Features:

- Heavy Duty
- 4" Diameter Deluxe Cutter
- Stainless Steel Components

Required Accessories:

- Drill Bit - 12.5mm
- 60° Live Center
- Woodworking Chuck
- Parting Tool
- 2 Part Epoxy Glue
- Wood Required: 1½" Square x 6" Long



DIAGRAM A / PARTS LAYOUT

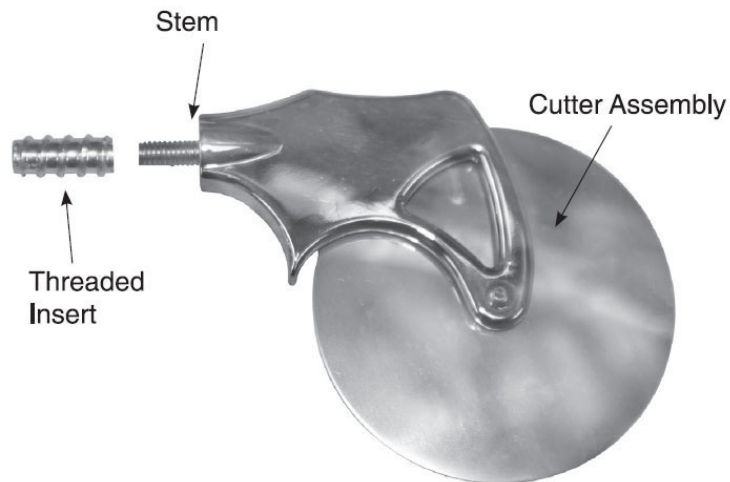
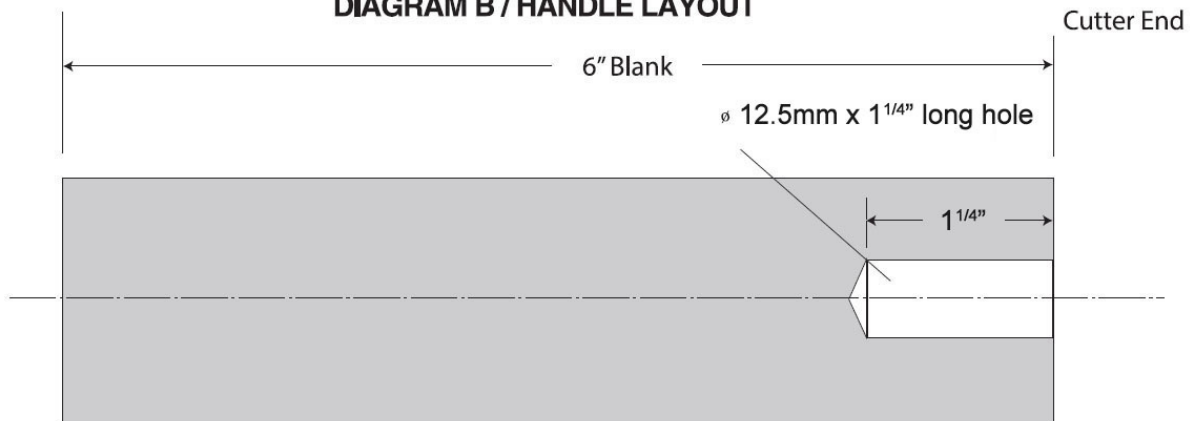
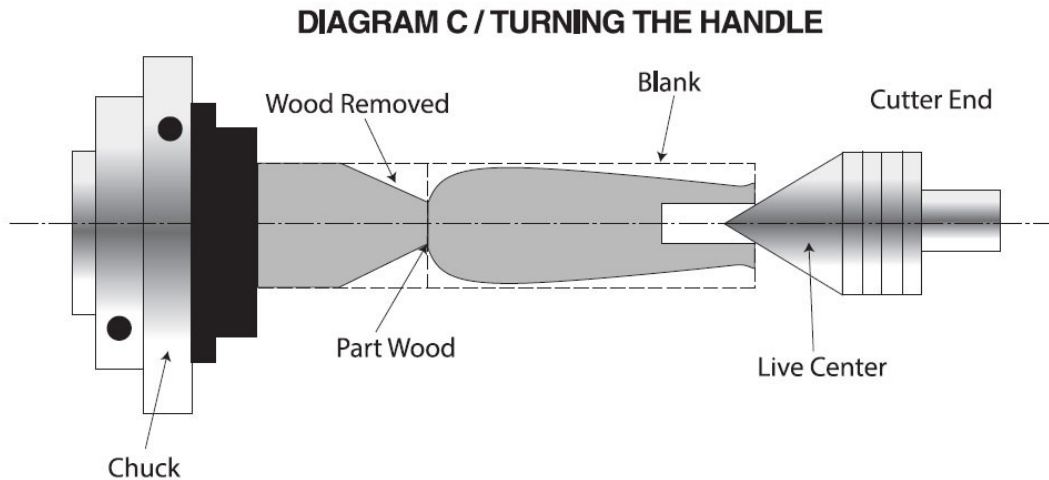

DIAGRAM B / HANDLE LAYOUT



Preparing The Handle (see Diagram B)

- Square the ends of the blank to start.
- Mark the center of the blank.
- Drill a 12.5mm hole, 1¼" deep, at one end.
- Make sure the holes are straight down center.
- Dry fit the threaded insert in the hole. The end of the insert should be flush with the wood.



Turning The Handle

- Bring the tailstock in, slide the centre into the hole at the opposite end. Lock in place.
- Turn the wood down to the profile design. Mark 4" long.
- Make diameter of the ends match the kit components.
- Part the handle off the wood at the mark.

Assembly

- Spread glue inside the hole in the handle.
- Slide the threaded insert in and set aside until the glue has dried.
- Screw the threaded stem into the threaded insert.