

Chalk Holder Kit

Kit Features:

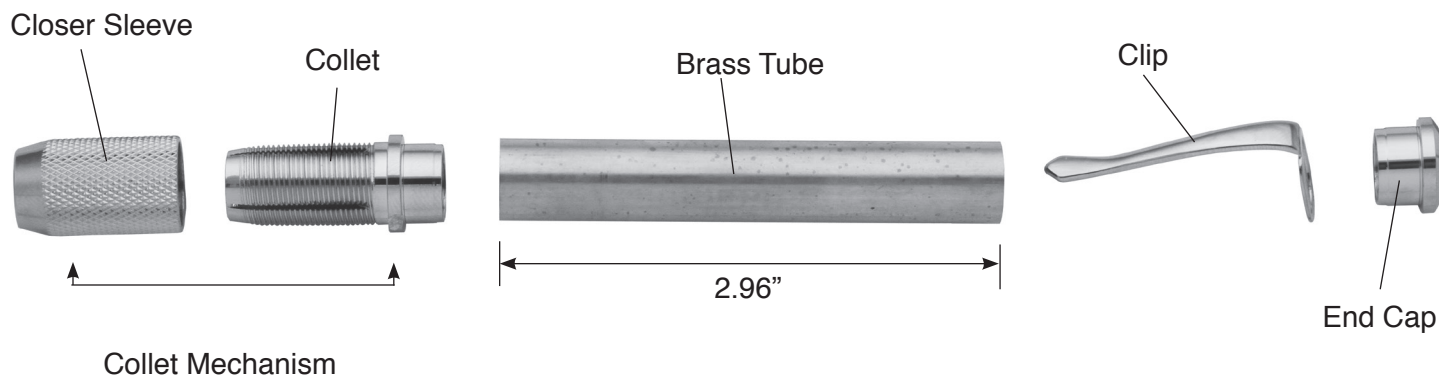
- Available in various finishes
- Securely holds chalk with collet
- Holds small chalk pieces
- Accepts standard chalk 3/8" x 3-1/4"
- Overall length - 4-1/2"
- Convenient pocket pen clip

Required Accessories:

- 7mm Pen Mandrel
- Drill Bit: 12.5mm #PKPLIDB
- #PKCKBU Bushing set (2 pc)
- Universal pen blank squaring jig #PKSQUARE or a disc / belt sander
- Live Tailstock Center
- 2 Parts Epoxy Glue or Insta Cure (Cyanoacrylate) Glue
- Pen Blank: Minimum Size - 3-1/4"

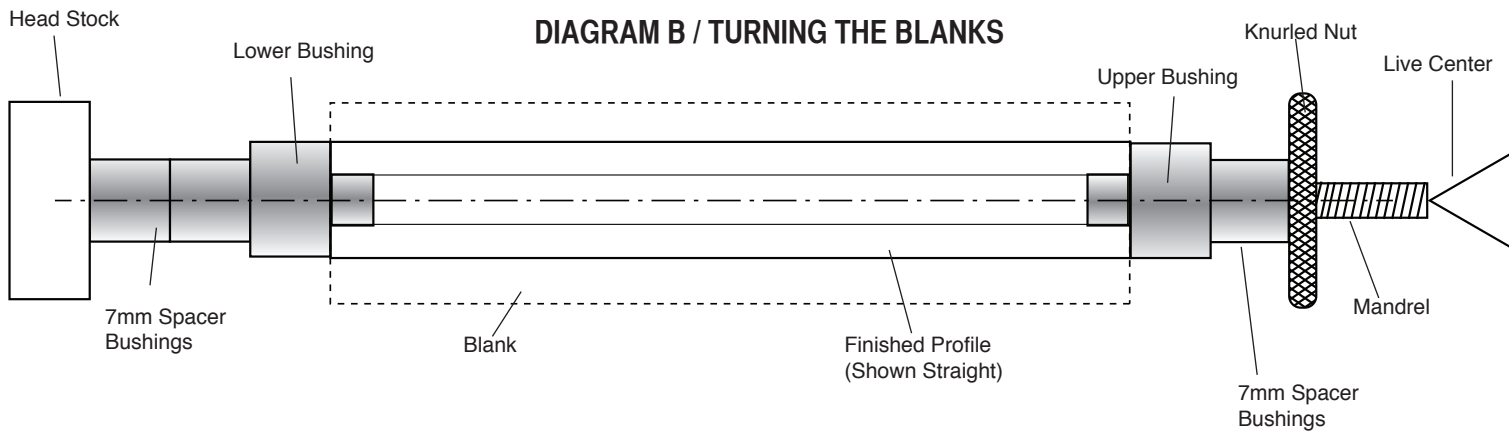


DIAGRAM A / PARTS LAYOUT



Preparing the Blank:

- Cut 1 blank to the length of the tube and add 1/16" for squaring off.
- Drill 12.5mm hole lengthwise through the blank.
- Spread glue over the tube(s), insert the blank with a twisting motion to spread the glue evenly inside. Center the tubes lengthwise inside the blanks.
- When the glue is dry, square the ends of the blanks. You can use a 7mm barrel trimmer with the proper sleeve, or a universal pen blank squaring jig with a power disc sander. Take the excess material down flush with the ends of the brass tube. Use a barrel trimmer to clean the inside of the tube.



Turning the Blank

- Mount the bushings and blanks according to diagram B.
- Thread on the knurled nut and hand tighten to hold all components in place.
- Slide the tailstock up snugly against the mandrel shaft inserting the live center point into the mandrel dimple, lock in place.
- Hand tighten the quill adjustment to firm up the mandrel. (DO NOT overtighten, it could damage the mandrel.)
- Using sharp tools, turn the blank down close to the bushing diameter. Turn the barrel (straight or to a profile of your choice)
- Sand the blank down to be flush with the bushings gradually increasing the sandpaper grits.
- Finish the barrel with your choice of polish. Allow sufficient time for the polish to cure. Refer to polish instructions.

Assembly

- Layout parts according to diagram A (collet & closer sleeve are pre-assembled)
- Slide the clip onto the end cap.
- Press the end cap and clip into either end of the turned barrel.
- Press the collet mechanism into the opposite end.
- Twist the closer sleeve so it opens the collet sufficiently to accept chalk.
- Insert chalk and tighten.
- To advance chalk, twist the collet mechanism open and pull or slide chalk forward.
- When not in use - push chalk inside collet and tighten.
- NOTE: chalk diameters may vary from manufacturer to manufacturer. If chalk is tight and does not slide inside the collet it may be necessary to unscrew and remove the closer sleeve to advance the chalk.

Diagram C / Bushings #PKCKBU

