

# Motorcycle Pen Kit

## Kit Features:

- Bold, authentic design
- Back end showcases replicas of genuine motorcycle parts
- Reliable Bolt Action mechanism resembles kick starter pedal
- Easy to Turn With Straight Tubes
- Minimal Parts - easy to assemble
- Available in multiple finishes
- Overall Length: 5-11/16"
- Uses Parker Style Refill #PKPARK-R5

## Required Accessories:

- 7mm Pen Mandrel
- Drill Bit: 10mm #PK10-10
- Bushing Set( 2 pc): #PKPT100BU
- Barrel Trimming set: #PKTRIM10 or 10MM sleeve from PKTRIMSET.
- Live Tailstock or Mandrel Saver
- 2 part Epoxy or Thick CA (Cyanoacrylate) Glue
- Pen Blank Minimum Size: 3/4" X 3/4" 2-5/16"



## DIAGRAM A / PARTS LAYOUT

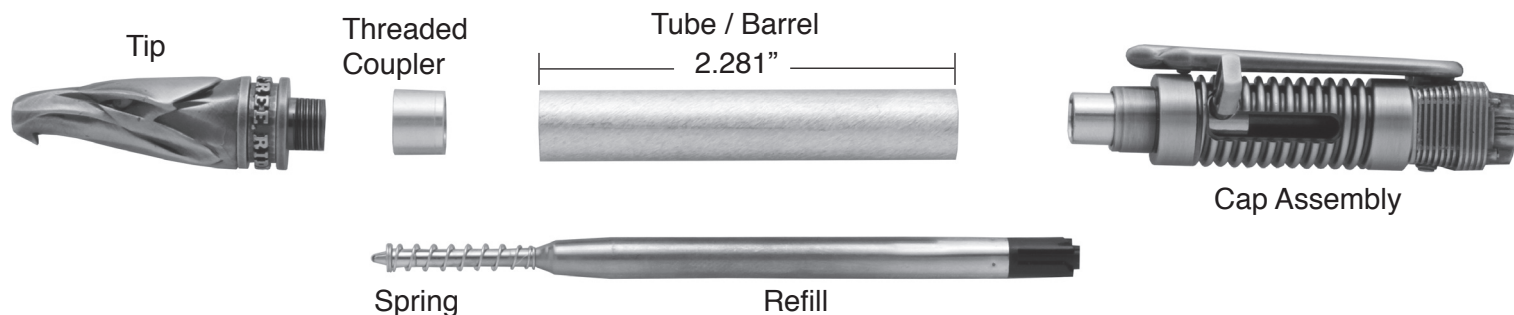

## Preparing the Blank:

- Cut blank to the length of the tube, adding 1/16" for squaring off.
- Drill 10MM hole lengthwise through the blank.
- Spread glue over tube, insert the tube into the blank with a twisting motion to spread the glue evenly inside.
- Center the tube lengthwise inside the blank.
- When the glue is dry, square the ends of the blanks, making sure the trimmed ends are 90° to the tube. Use a 10MM barrel trimmer, or a pen blank squaring jig with a 10MM sleeve on a disc sander. Take the excess material down flush to the ends of the tubes. Do not trim past the end of the tube since this may interfere with the operation of the mechanism and assembly. Use a barrel trimmer to clean the inside of the tube.

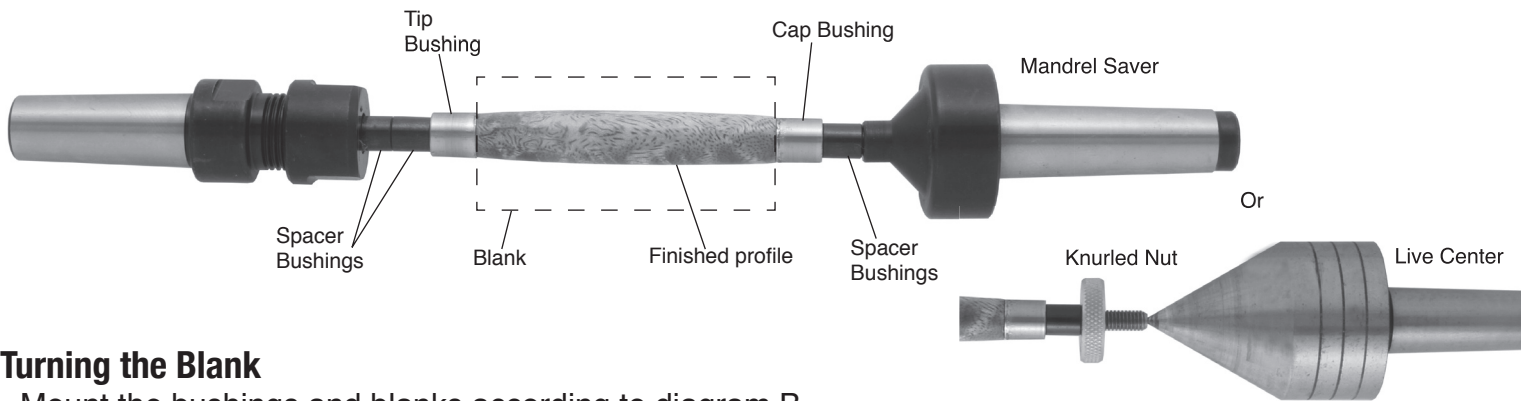
**DIAGRAM B / TURNING THE BLANKS****Turning the Blank**

- Mount the bushings and blanks according to diagram B.
- Thread on the knurled nut and hand tighten to hold all components in place.
- Slide the Tailstock up snugly against the Mandrel shaft, inserting the live center point into the Mandrel dimple. Lock Tailstock.
- Hand tighten the quill adjustment on the tailstock to steady the mandrel. Do not over tighten, it could damage the mandrel shaft.
- When using Mandrel Saver, there is no need for extra spacer bushings or the knurled nut. Slide tailstock directly against bushings and tighten until blank and bushings are secure.
- Using sharp tools, turn the blank down close to the bushing diameter. Turn the barrel straight or to a profile of your choice.
- Sand the blank down to be flush with the bushings, gradually increasing sandpaper grits.
- Finish the barrel using your choice of polish. Allow Sufficient time for the polish to cure—refer to polish instructions.

**Assembly**

- Line up parts according to Diagram A.
- Press Back End Assembly into either end of blank.
- Thread Tip nut onto Tip.
- Align Tip orientation so that the side of the eagle lines up with the Kick Starter
- Push Tip Nut in by hand until it wedges into tube.
- Unscrew Tip, taking care not to alter tip nut and use press to fully insert Tip Nut.
- Insert Refill, Back end first, into opening in Tip Nut.
- Put spring onto shaft of Refill (See Diagram A for spring orientation).
- Thread Tip over refill.
- To operate, slide Kick Starter down and over into side slot to extend. Move out of slot and allow to slide back to retract.
- To change refill, unscrew Tip. Remember to transfer Spring to new Refill.

**Diagram C / Bushings #PKPT100BU**