

# CARPENTER PENCIL

## Kit Features

- Easy to Turn with a Straight Tube
- Minimal Parts—easy to assemble
- Available in multiple finishes
- Refill: 2mm Lead #PKPOWLEAD
- Includes Sharpener
- Overall Length: 5-3/4"

## Required Accessories

- 7mm Pen Mandrel
- Drill Bit: #PK-38BP for Wood, #PKEXEC-38 for Plastic
- Bushing Set(2pc): #PKMAJSQBU
- Barrel Trimming: #PKTRIM 38 or 3/8" sleeve from #PKTRIM-SET with squaring jig on disc sander
- Live Tailstock or Mandrel Saver
- 2 part Epoxy or Thick CA (Cyanoacrylate) Glue
- Pen Blank Minimum Size: 3/4" x 3/4" x 3-3/16"L

## Preparing the Blank:

- Prior to cutting and gluing, always verify tube length is correct (see parts diagram on back page)
- Cut blank to the length of the tube, adding 1/16" for squaring off.
- Drill 3/8" hole lengthwise through the blank.
- Spread glue over tube, insert the tube into the blank while twisting to spread the glue evenly inside.
- Center the tube lengthwise inside the blank.
- When the glue is dry, square the ends of the blanks, making sure the trimmed ends are 90° to the tube. Use a 3/8" Barrel Trimmer or 3/8" barrel trimming sleeve with a pen blank squaring jig on a disc sander. Take the excess material down flush to the ends of the tubes. Do not trim past the end of the tube since this may interfere with assembly and the operation of the mechanism. Use a barrel trimmer to clean the inside of the tube.



## DIAGRAM B / TURNING THE BLANK

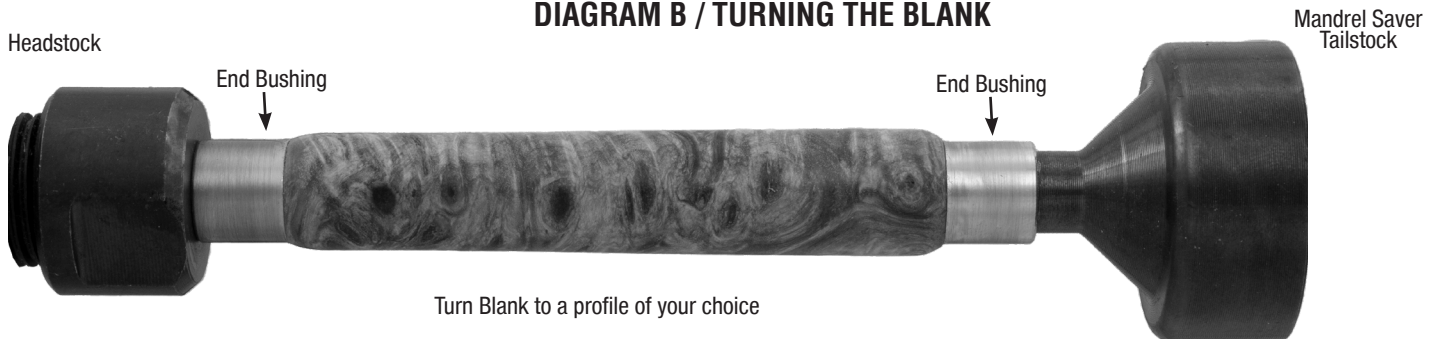

## Turning the Blank:

- Mount the bushings and blanks according to diagram B.
- When using Mandrel Saver, there is no need for extra spacer bushings or the knurled nut. Slide and lock tailstock directly against bushings and tighten quill until blank and bushings are secure.
- To use Knurled Nut Setup (right), add spacer bushings until past the threads on the end of the Mandrel Shaft.
- Thread on the Knurled Nut and hand tighten to hold all components in place.
- Slide the Tailstock up snugly against the Mandrel shaft, inserting the live center point into the Mandrel dimple.
- Lock Tailstock and hand tighten the quill adjustment with wheel to steady the mandrel. Do not over-tighten, it could damage mandrel shaft.
- Using sharp tools, turn the blank down close to the bushing diameter. Turn the barrel straight or to a profile of your choice.
- Sand the blank down to be flush with the bushings, gradually increasing sandpaper grits.
- Finish the barrel using your choice of polish. Allow sufficient time for the polish to cure—refer to polish manufacturer's instructions.

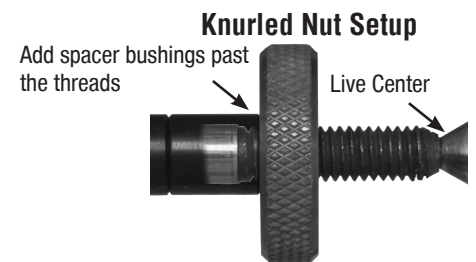

## Diagram C / Bushing #PKMAJSQBU

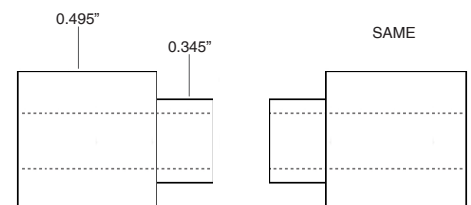

## Diagram D / Parts Layout

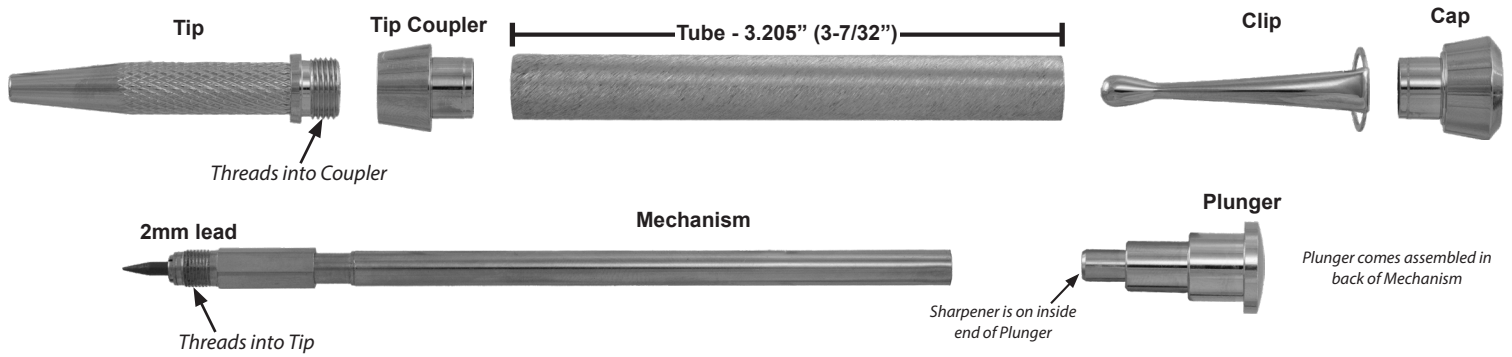

## Assembly:

- Press Cap, through the Clip, into either end of the Barrel.
- Press the Tip Coupler into the remaining, open end of Barrel.
- Pull Plunger to remove it from the back of the mechanism.
- Thread front of Mechanism into the front of Tip.
- Insert back of Mechanism/Tip assembly fully through the Tip Coupler and thread into the Tip Coupler.
- Push Plunger back into the top of the Mechanism until it seats.
- Push Plunger repeatedly to extend the lead.
- The lead does not come sharpened. To sharpen, press plunger to extend lead out at least 3/8". Pull Plunger from top.
- The bottom of the Plunger Assembly is where the hole for the Sharpener is located. Insert over lead and twist to sharpen.
- NOTE: When twisting Plunger to sharpen, always twist counter-clockwise (from the perspective of looking at the top of the Plunger). Twisting in the opposite direction can unthread the mechanism from the tip. See Diagram E.
- Once lead is sharpened: Replace Plunger into back of Mechanism, press down and hold Plunger so lead can be pushed back into the Tip.
- 2mm pencil refills are available. Item #PKPOWLEAD. New refills can be inserted into the back of the Mechanism after pulling out Plunger.

## Diagram E / Sharpening

