

Deluxe Pizza Cutter Kit

Kit Features:

- Heavy Duty
- 4" Diameter Deluxe Cutter
- Stainless Steel Components

Required Accessories:

- Drill Bit - 1/2"
- 60° Live Center
- Woodworking Chuck
- Parting Tool
- 2 Part Epoxy Glue
- Wood Required: 1-1/2" Square x 6" Long



DIAGRAM A / PARTS LAYOUT

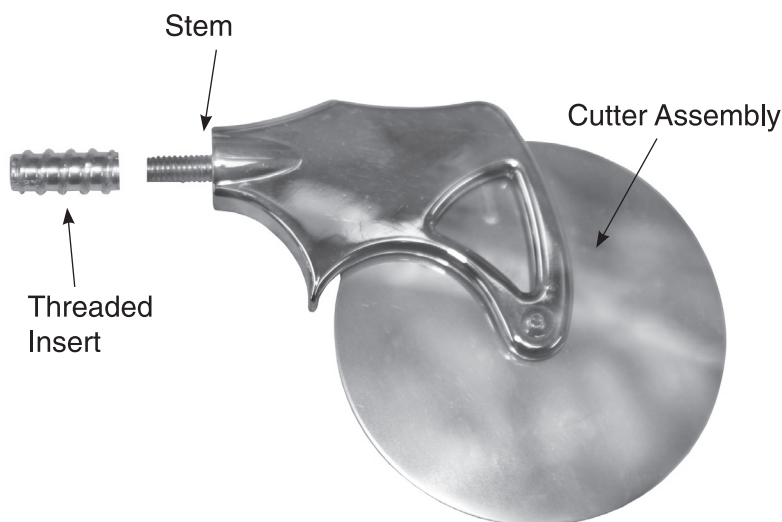
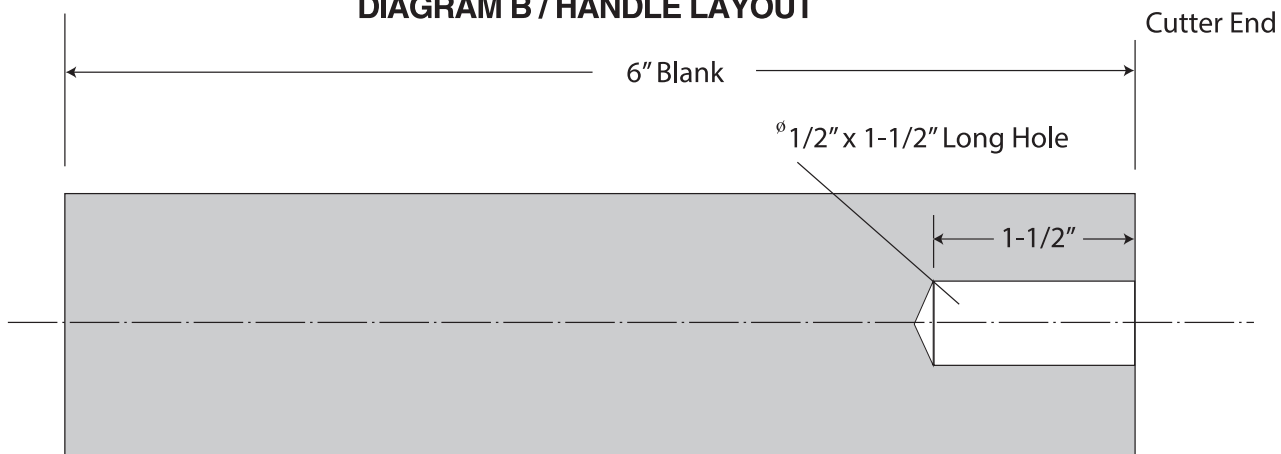

DIAGRAM B / HANDLE LAYOUT



Preparing The Handle (see DIAGRAM B)

- Square the ends of the blank to start.
- Mark the center of the blank.
- Drill a 1/2" hole, 1-1/2" deep at one end.
- Make sure the holes are straight down the center.

DIAGRAM C / TURNING THE HANDLE

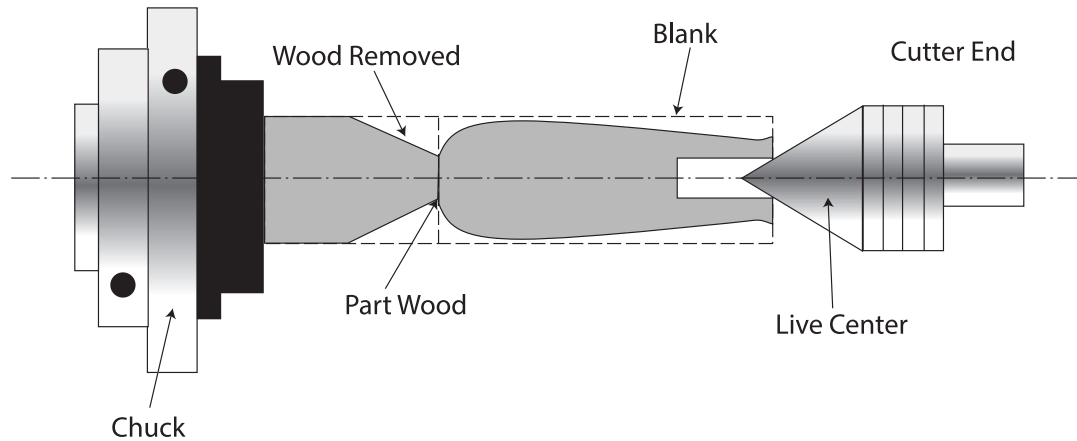

Turning The Handle

- Bring the tailstock in, slide the center into the hole at the opposite end. Lock in place.
- Turn the wood down to the profile design. Mark 4" long.
- Make the ends diameter match the kit components.
- Part the handle off the wood at the mark.

Assembly

- Thread the insert over the stem.
- Spread glue inside the front hole at the handle.
- Slide the assembly in, be sure it will dry straight.
- The pizza cutter is ready to use.