

Heirloom Pepper Grinder

HL-GRIND-XX

william wood-write

penblanks.ca

Needed:

- 1" Forstner Bit
- 1-3/4" Forstner Bit
- 5/16" Drill Bit
- 1" Jam Chuck
- 60 Degree Live Center
- 3 Jaw Drill Chuck or Collet Chuck
- Minimum Recommended Blank Size: 2 1/2" to 3" square x 4" long



Preparing the Blank for Recessed Mounting (Diagram A):

1. Mark the center of the blank.
2. Drill a 1 3/4" hole 1/4" deep into the center of one end of the blank.
3. Drill a 1" hole through the center of the blank. Tip: Drilling these holes on the lathe will keep things centered.
4. Using the peppermill as a template (Diagram A is not a full scale template), center the peppermill over the 1 3/4" hole and mark the position of the mounting holes. Drill the mounting holes with a 5/16" drill 1/4" deep.

Mount the Blank on the Lathe (Diagram B):

1. Mount a drill chuck or collet into the headstock of the lathe and attach the jam chuck.
2. Insert the recessed end of the blank onto the jam chuck. Tighten the nut on the jam chuck to expand it into the hole until it is firmly held in place.
3. Bring the 60 degree live center up and into the hole in the other end of the blank to secure it in place. Lock down the tailstock.

Diagram A

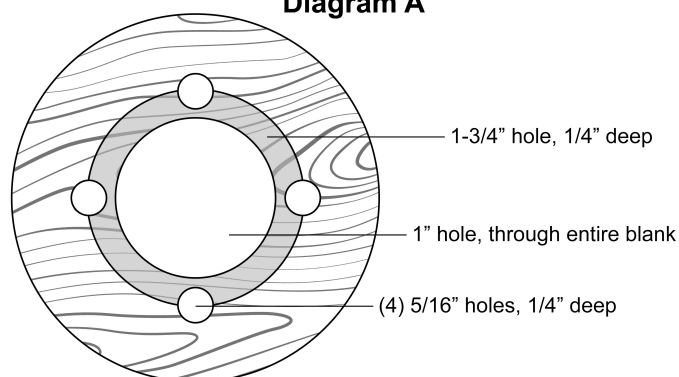

Turning the Blank:

1. Turn the blank to your desired shape.
2. Sand and coat with food safe finish.

Mounting the Mechanism:

1. Insert the base into the recess.
2. Drill two pilot holes for the screws. Drilling on a slight inward angle makes it easier to install the screws.
3. Screw the base into the wood.

Diagram B

